

Home security - a simple guide to what products to use where

It is worth remembering that 8 out of 10 burglaries are committed by opportunist thieves – in fact in 20% of cases, the burglar enters through a door or window that has been left open. Burglars are always on the lookout for an easy target so a few simple and cost effective precautions will help to put them off.



Door security

Most front doors are fitted with a **nightlatch**, which latches automatically when the door is closed, but can be opened from inside without a key. These provide a measure of security but can be forced by thieves so shouldn't be relied upon on their own.

All external doors should be fitted with a kitemarked lock or nightlatch certified to BS 3621. For timber doors we would recommend a BS 5 lever mortice deadlock or a sashlock. A door fitted with one of these can only be opened with a key, so a thief can't smash a glass panel or climb in through a window to open it from the inside.

An extra measure of security can be provided by fitting rack or tube bolts, top and bottom, to all exterior doors.

Perimeter security

Garden theft is on the rise and sheds and garages can also be vulnerable.

A strong, lockable gate fitted across a side passage will prevent a thief getting to the rear of a property. These can be secured using a rim lock or padlock and hasp.

Fit shed and garage doors with a strong padlock and hasp. Where there is a connecting door to the house this should be treated as an external door and fitted with a BS kitemarked lock.

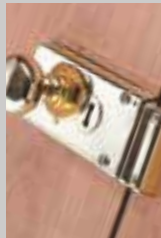

Residential entrance security

Timber Door Construction

The door itself should be at least 44mm thick and constructed of solid timber with any panels a minimum of 14mm thick. The door frame must be solid and securely fixed to the walls at least every 600mm around the whole frame.

Any glass panels should be laminated security glass or have a metal grid or polycarbonate shield on the inside.

Door Hardware

The hardware fitted to the door can have a significant effect on security and as a consequence this can reduce the cost of some insurance policies. Please ensure you check the particulars of your own policy.

1. A good quality automatic deadlocking nightlatch should be fitted approximately 1/3 of the way down the door.
2. A good quality 5 lever mortice deadlock should be fitted approximately 1/3 of the way up the door. This should be a kitemarked lock to BS3621:2007 + A2:2012.
3. A door viewer allows the occupant to see who is at the door before opening the door.
4. A door chain allows the occupant to check who is calling without having to fully open the door.

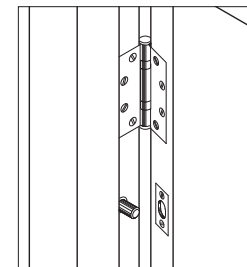
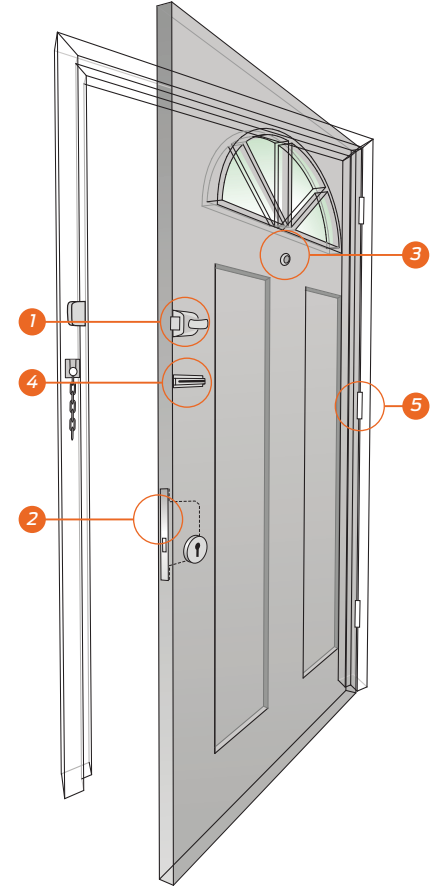

5. Hinges

The door should be fitted with at least three, 100mm hinges. The hinges should be selected to suit the weight of the door and are generally available to suit different door thicknesses. The hinges should be in accordance with BS EN 1935.

Hinge Bolts

It is recommended to fit two or three hinge bolts midway between the hinges. These are essential if the door opens outwards as it prevents the door being opened by cutting or grinding off the hinge knuckles.